



EN

Quick Installation Guide

**1/3" HDcctv Camera, 3D-DNR,
Day&Night, 1920x1080, 2.8-
10mm, RS-485, infrared,
12/24V**

HDB-2080M2810IR D

Safety Precaution

- To prevent fire or shock hazard, do not expose the unit to rain or moisture.
- To prevent electric shocks and risk of fire hazards, do NOT use other than specific power source.

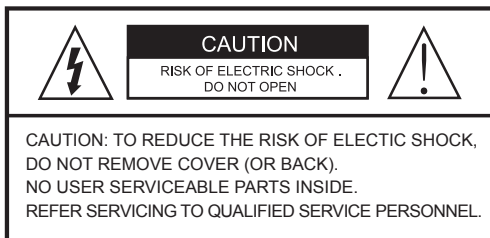

The symbol is intended to alert the user to the presence of uninsulated "dangerous voltage" within the product's enclosure that may be of sufficient magnitude to constitute a risk of electric shock to persons.



The symbol is intended to alert the user to the presence of important operating and maintenance(servicing) instructions in the literature accompanying the unit.

• Warning :

This equipment has been tested and found to comply with the limits for a Class A digital device, pursuant to part 15 of the FCC Rules. These limits are designed to provide reasonable protection against harmful interference when the equipment is operated in a commercial environment. This equipment generates, uses, and can radiate radio frequency energy and, if not installed and used in accordance with the instruction manual, may cause harmful interference to radio communications. Operation of this equipment in a residential area is likely to cause harmful interference in which case the user will be required to correct the interference at his own expense.

• Caution :

Any changes or modifications in construction of this device which are not expressly approved by the party responsible for compliance could void the user's authority to operate the equipment.

Mains power quality should be that of a typical commercial environment. If the user of the model requires continued operation during power mains interruptions, it is recommended that the model be powered from an uninterruptible power supply (UPS) or a battery.

Safety Precaution

NOTICE

- The image used in this instruction manual are processed to help comprehension and may differ from actual video of the camera.
- Avoid installing areas where has shock or vibration which results in the problems.
- Pay attention to safety when laying the connection cable and observe that the cable is not subjected to heavy loads, kinks or damage and no moisture can get in.
- Never open the device such as boards or lens.
The warranty becomes void if repairs are undertaken by unauthorized persons.
- Maintenance and repair have to be carried out only by authorized service centers.
- Use only a mild detergent to clean the housing.
- The camera should never be operated beyond the technical specifications.
This can lead to destruction.
- The camera should never be operated in water.

Contents

p.03~04

Safety Precaution

p.05

Contents

p.06~07

Features

p.07

Composition

p.08

Dimensions

p.09

Part Names

p.10~12

Installation Instructions

p.13~29

Operating Instructions

p.30~31

Specifications

Features

Key Features

- Full HD, 2Mega Pixel EX-SDI CAMERA, 1920x1080(30p/25p)
- Extended long reach HD Solution
- Real time True WDR(Wide Dynamic Range) / 30fps
- Improved noise figure with the enhanced 3DNR
- Built-in f=2.8~10mm F1.4, Mega-pixel DC Auto Iris vari-focal lens
- Dual Filter Switcher
- Day & Night Simulation for easy focus adjustment
- Various Zooming Technologies
 - Pointing Zoom (which enables the programmable zooming at any area)
 - Preset Zoom
 - Flex Zoom
 - Smart Motion Zoom (Automatic zoom in/out when motion is detected)
- Motion Detection, Privacy Mask, Defog, Sens-up(~x32), D-WDR, H/V/HV Flip, D-Zoom(~8x), Lens Shade Compensation, BLC/HLC, Pixel Defect Compensation, Title Set
- EX-SDI or HD-SDI switchable
- Top performance at low light sensitivity (Sens-up On)
- OSD menu & CVBS Video output BNC for easy installation & maintenance.
- Circuit protection against faulty connection in power polarity
- Isolated power supply against ground loop problem
- Remote control via RS-485 (Pelco-D/P)
- Quick Firmware update via RS-485
- Operable up to -50°C
- External Zoom & Focus adjustment
- Built-in 40pcs LEDs
- LED ON/OFF Control
- Dual Window
- Built-in Heating function
- One-touch 3-Axis locking bracket, Easy Installation Pad
- IP67 protection

Features

General Description

This camera realizes the natural and crisp image as you see the scene in front of you by Full HD(1920x1080p) camera module.

Highly detailed pictures can be achieved and color reproducibility deserves attention.

- With ICR mechanism,
 - Enhances its sensitivity about 10x at night time
 - Can accept the infrared light
- With Intelligent Focus Indicator and FOCUS ASSIST menu,
 - Offers easy adjustment of Focus
 - Eliminates the mistake of the erratic focus adjustment
- With 24VAC/12VDC dual power design,
 - Offers the flexibility of installation
 - Ensures the reliability

Composition

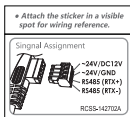
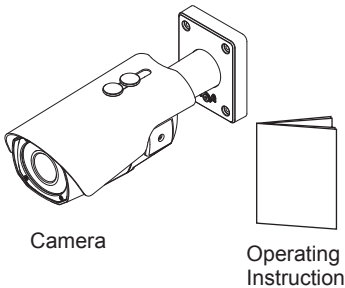

Cable Signal Sticker

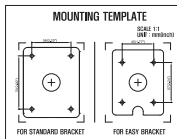

Mounting Template

Plastic Anchor:
6 x 30mm (4pcs)



Mounting Screw:
4 x 30mm (4pcs)



Assembly Screw:
4 x 14mm (4pcs)



Torque Wrench:
3mm (1pc)



Wiring Connector:
(1pc)

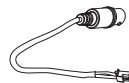

Video Sub-out Cable (1pc)

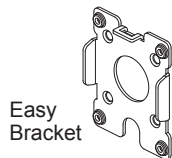

Easy Bracket

Dimensions

(unit : mm)

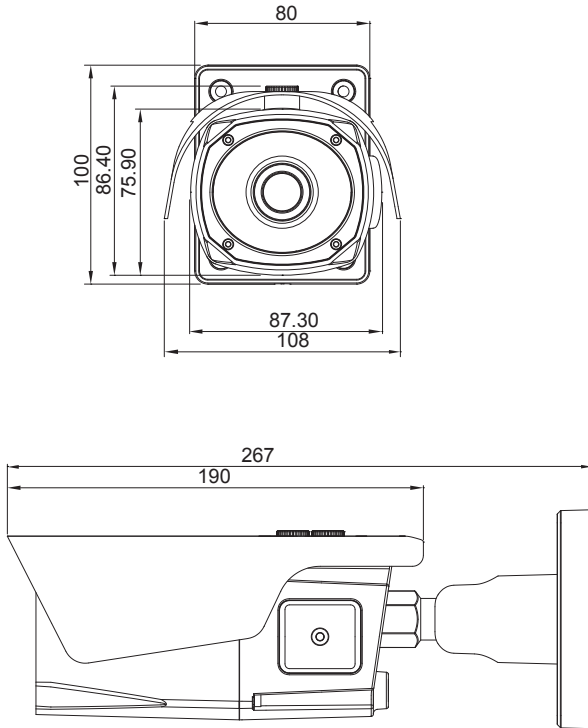

CAUTION

- Extreme care should be taken NOT to scratch the window in front of lens.
- Care should be taken the cable is NOT to be damaged, kinked or exposed in the hazardous area.
- Do not expose the camera directly to a strong light source such as the sun or spot light.

Part Names

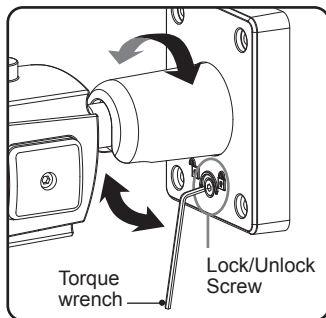
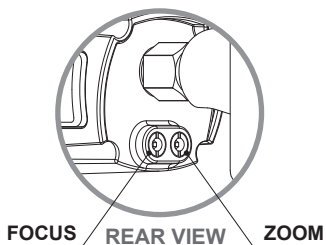
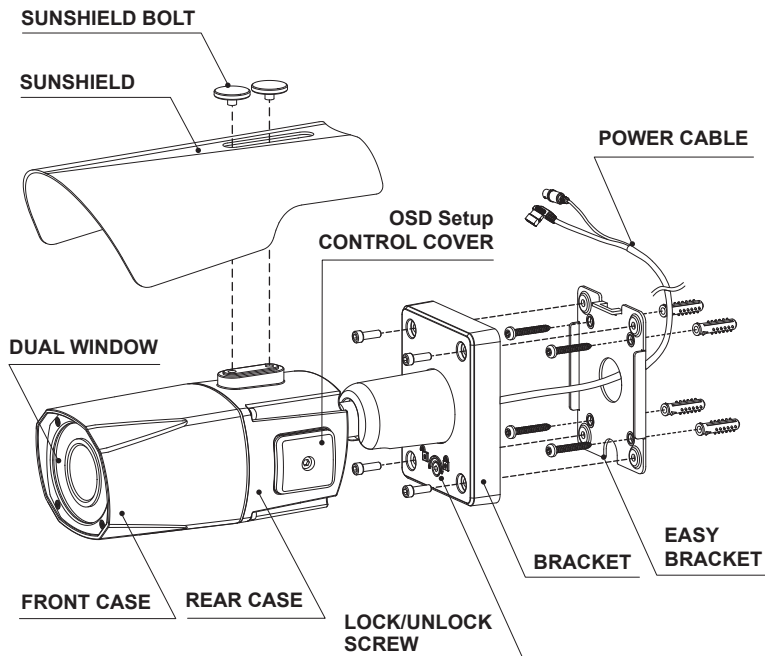

■ Adjustment of viewing angle with a bracket

Installation Instructions

1. Locate the mounting template at the installation position and drill the ceiling or wall if needed. (*The easy bracket can not be installed on the ceiling)
2. Place the easy bracket on pre-drilled position and fix it through using mounting screws (4x30mm). Skip this step when an easy bracket is not installed.
3. Route the Power cable to the connecting place.
Hook up the camera bracket with the easy bracket as illustrated below.
4. Fix the camera bracket through using assembly screws (4x14mm).
5. Set the camera's viewing angle and adjust zoom/focus of lens by using the torque wrench.
6. Put the sunshield to the camera unit and tighten the sunshield-bolts.

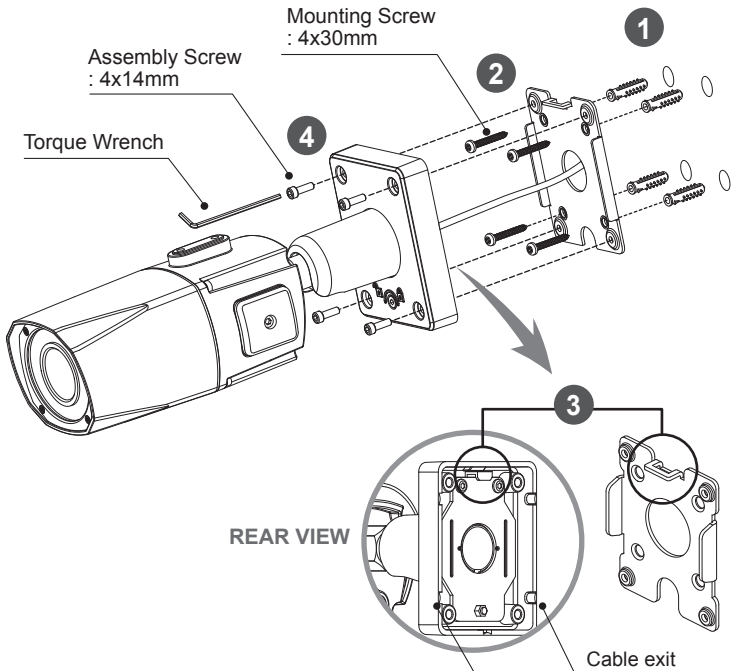

Installation Instructions

Pan & Tilt adjustments

- Unlock the screw on the camera bracket through using the torque wrench supplied
- Set the camera's viewing angle then lock the screw on the bracket.

1) Pan limit:

Pan is limited to $\pm 90^\circ$.

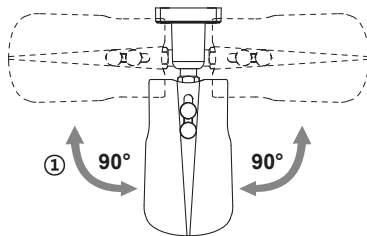

2) Tilt limit:

Tilt is limited to $0^\circ(2^\circ)$ min $\sim 90^\circ$ max. for wall(ceiling) installation respectively with reference to the wall(ceiling) when the inclination of camera module is 0° , that is, the image is aligned horizontally.

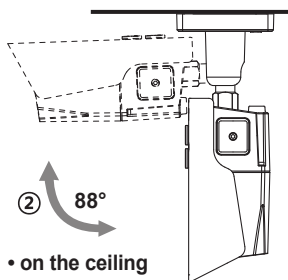
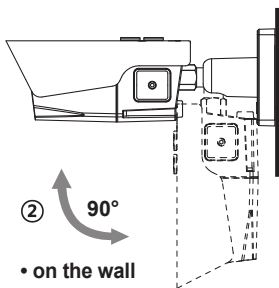

3) Inclination limit

(Horizontal image alignment):
Inclination limited to $\pm 90^\circ$ max.

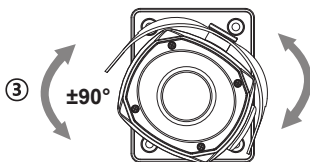

Zoom & Focus adjustments

Use the torque wrench supplied.

- Turn the Focus gear to "N"(Near) or " ∞ "(Far) until the sharpest focus is made.
- To widen the viewing angle, turn the Zoom to "W"(Wide) and to obtain a closer view, turn it to "T"(Tele)

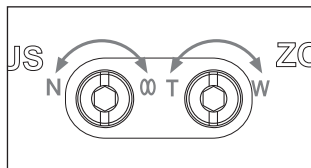

Installation Instructions

Power Supply Connections

Make sure the power is removed before the installation.

Camera can work with either 24AC or 12VDC, dual voltage power .

Primary and secondary grounds are completely isolated to avoid the possible ground-loop problems

In case that HD-SDI/EX-SDI Inputs are not supported in Monitor, please use HD-SDI/EX-SDI Converter to connect HD-SDI/EX-SDI cable with Monitor

Some computer monitors or TVs may not support 30p/25p.

In this case, HD-SDI/EX-SDI DVR which can convert the frame rate to 60p/50p is highly recommended.

Please check Specification of Monitor before installation.

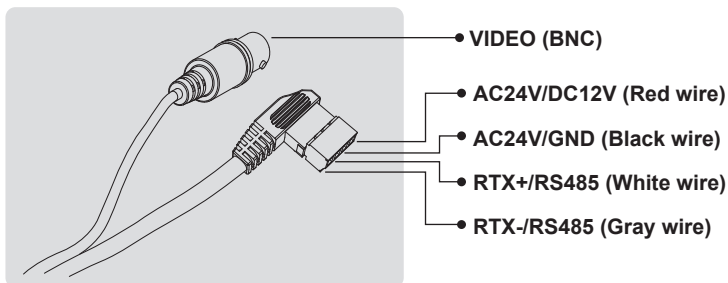

※ Attach the Signal Assignment Sticker in a visible spot for wiring reference.

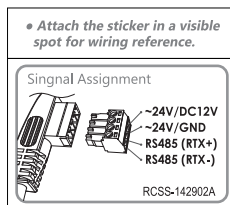

Operating Instructions

Using OSD controller

Setup menu can be accessed and controlled by OSD control joy stick on the side of camera unit.

Five commands are available with the joy stick.

The design of OSD could be different according to the Model.

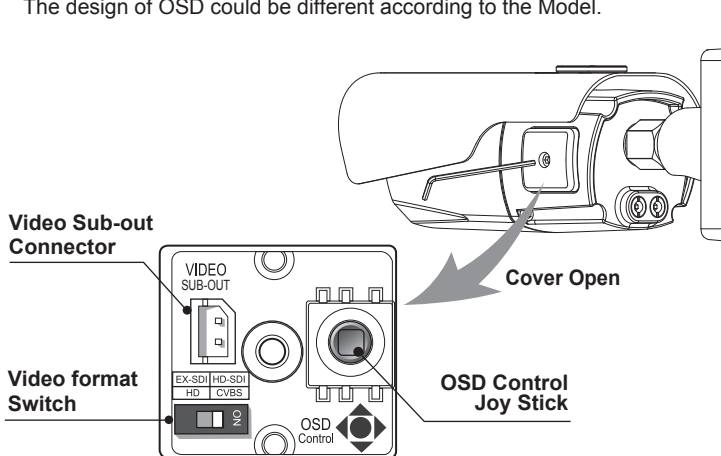

◆ Description of the joystick operation

- 1) SET Key (●) : Access to the menu or enter the setting.
To enter the main menu, press the Set Key down for about 1.5sec
- 2) UP/DOWN Key (▲/▼) : Choose the desired sub-menu and to move the cursor up or down.
- 3) LEFT/RIGHT Key (◀/▶) : Set up the value of the selected menu.
Used to adjust the desired menu selection and to move the cursor left or right.
- 4) '⏏' denotes the long press down straightly for about 2 seconds

◆ Description of the D-ZOOM* adjustment

(*) Works only when OSD menu is inactive.

- 1) ▲ : Zoom In
- 2) ▼ : Zoom Out

Operating Instructions

Set the video format according to system,
EX-SDI or HD-SDI

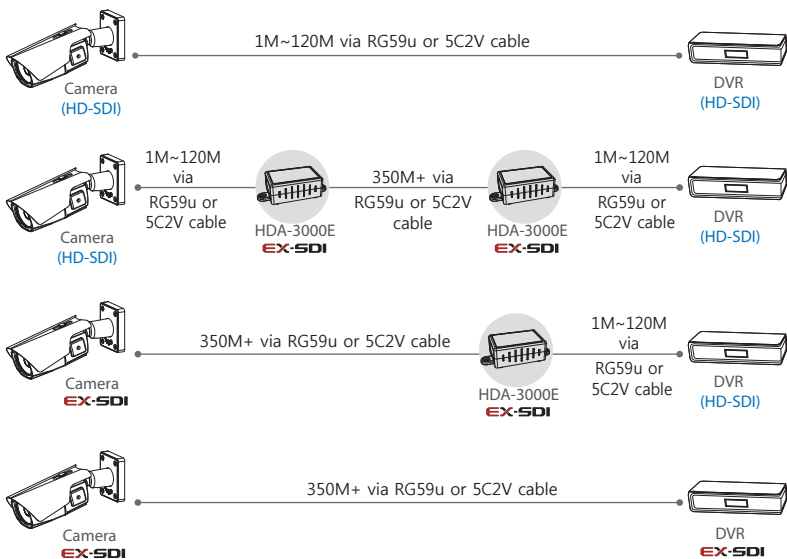

Operating Instructions

OSD menu Startup

Press '●' (OSD menu Joy stick key) down for about 2 seconds to access the setup menu mode.

| MENU V5.xx | |
|-------------------|-------------|
| 1. EXPOSURE | ↵ |
| 2. LENS | DC ↵ |
| 3. FOCUS ASSIST | ↵ |
| 4. SCENE ENHANCE | NORMAL |
| 5. 3D-NR | MID |
| 6. DAY/NIGHT | EXT ↵ |
| 7. PICT ADJUST | ↵ |
| 8. SPECIAL | ↵ |
| 9. SYSTEM | ↵ |
| A. EXIT | SAVE&EXIT ↵ |

Direct Control menu

| MAIN | DEFAULT | DESCRIPTION |
|---------------|-------------------|--|
| EXPOSURE | - | Sets EXPOSURE MODE, BRIGHTNESS, SENS-UP, AGC and MOTION DEBLUR. |
| LENS | DC | Sets Lens types. |
| FOCUS ASSIST | - | Sets FOCUS |
| SCENE ENHANCE | NORMAL | SCENE ENHANCE provides the several ways to enhance the video in the various environments with the settings in NORMAL, WDR, D-WDR, BLC and HLC. |
| 3D-NR | MID | Sets 3DNR level. LOW, MID, HIGH |
| DAY/NIGHT | EXT or AUTO | Sets DAY / NIGHT to EXT, AUTO, COLOR, B/W and COLOR D/N. Setting EXT mode for cameras with IR-LED, AUTO mode for none IR-LED camera types. |
| PICT ADJUST | | Sets WHITE BAL, SHARPNESS, COLOR GAIN, GAMMA |
| SPECIAL | | Sets MIRROR/FLIP, PRIVACY, MOTION, PIXEL DEFECT, TITLE SET, DISPLAY, DEFOG, POINTING ZOOM |
| SYSTEM | | Sets TV SYSTEM, RESOLUTION, COMM.SETUP, LANGUAGE and FACTORY DEFAULT |

Operating Instructions

EXIT

SAVE & EXIT – Exits the menu after saving the parameters.
EXIT – Exits the menu without saving the menu.

1. EXPOSURE

| EXPOSURE | |
|------------|-------------|
| ▶ SHUTTER | AUTO |
| BRIGHTNESS | :.....: 10 |
| SENS-UP | OFF |
| AGC | :.....: 12 |
| RETURN | RET ↵ |

1-1. SHUTTER (default: AUTO)

: Can set EXPOSURE MODE to AUTO, MANUAL and Flickerless. MANUAL and Flickerless modes disable SENS-UP and MOTION BLUR functions.

- AUTO: Optimizes the video level by controlling the iris and the shutter speed automatically.
- MANUAL: Iris and Shutter can be set to fix.
- Flickerless : Reduces the flicker in video when US(60Hz)/EU(50Hz) mode is used in 50Hz/60Hz fluorescent lighting respectively.

1-2. BRIGHTNESS (default: 10)

: Adjusts the brightness of video(0~20).

2-3. SENS-UP (default: AUTO)

: The brighter video can be obtained by increasing the exposure time in the night with SENS-UP. SENS-UP is the maximum integrations of frame by DSS (Digital Slow Shutter) in the low light.

- AUTO: SENS-UP is enabled or disabled automatically by the scene brightness. Higher SENS-UP can get the brighter video but the slower frame rates with motion blur and more white pixels. If set to AUTO, maximum integration limit for SENS-UP can be set to x2, x4, X8, x16, X32 in SENS-UP menu.
- OFF: Disables SENS-UP.

2-4. AGC (default: 12)

: AGC(0~20) amplifies the video gain for brighter video but noise and white pixel accordingly. AGC level less than 10 disables AUTO in DAY/NIGHT.

Operating Instructions

2. LENS

Lens can be selected either DC or MANUAL lens.

Lens MUST be set to DC for the best image when DC iris lens is installed

2-1. DC (default: INDOOR)

: Selects lens mode according to installation place. INDOOR or DEBLUR for indoor installation according to environment.

- INDOOR: Optimized of indoor environment.
- OUTDOOR: Optimized of outdoor environment.
- DEBLUR: It enables to reduce the blur in a certain indoor environment.
Noise or color rolling can increase.

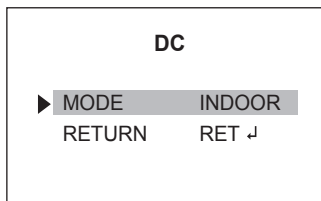

2-2. MANUAL (default: NORMAL)

: Horizontal wave or bar may be seen when MANUAL is selected and the camera is working under florescent or similar lights.

- NORMAL: Optimized of indoor environment.
- DEBLUR: It enables to reduce the blur in a certain indoor environment.
Noise or color rolling can increase.

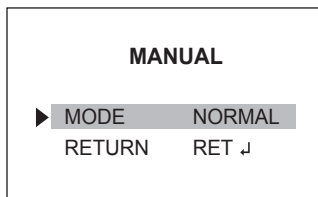

3. FOCUS ASSIST

Usually cameras are installed in the day time and they often become OUT OF FOCUS at night time and IN FOCUS again at next day time.

This problem can occur at any cameras regardless of types or manufacturers.

FOCUS ASSIST menu is the unique and patented feature that prevents from the wrong focus and helps the EXACT NEEDLE focus by simulating DAY & NIGHT conditions. Set zoom first and adjust focus to get NEEDLE FOCUS while switching at DAY & NIGHT.

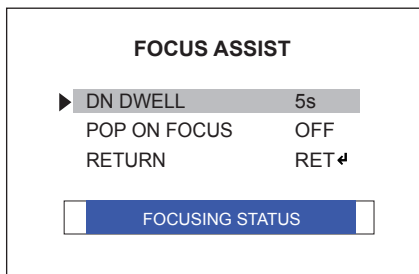

- DN DWELL (5s) : ICR switcher switches DAY & NIGHT at the interval of D/N DWELL to help the EXACT NIDDLE focus at DAY and NIGHT mode.
Further simulations are performed internally during switching.

Operating Instructions

- **POP ON FOCUS (OFF) :**
ON zooms in the center of picture at 2X for better focusing.
- **FOCUSING STATUS (ON) :** Shows how exactly focus is set. When blue bar doesn't show up, try the lens focus to NEAR and FAR. The maximum blue bar indicates the best focusing position.

4. SCENE ENHANCE

4-1. NORMAL (default)

: Optimized for the normal indoor and outdoor in the good lighting condition.

4-2. WDR

: Improves the visibility for the high bright area and the dark area by the double captures of image with LONG and SHORT exposures. With WDR ON, the frame rate becomes half by the double captures. WDR level can be selected from LOW, MID and HIGH. Care should be taken to select this mode because video may lose its quality in some environments by the over compensation.

※ CVBS video signal: Connecting 2nd video to CVBS port disables WDR function temporary. It should be considered when installer adjusts the video with installation monitor via CVBS video signal.

4-3. D-WDR

: Improves the visibility by compensating the video gain for the dark area.
Noise can increase in the dark area accordingly.

4-4. BLC

: Improves the visibility for the dark object by the bright back light.
Outside area of BLC window can over saturate.
BLC has a target window for compensation and its size and position can be set by H-POS, V-POS, H-SIZE and V-SIZE.

4-5. HLC

: Cuts out the highlight area with black mask and excludes it from compensation.
Lower HLC LEVEL cut out video from the lower level.

5. 3D-NR

3D-NR is a very sophisticated and powerful time-based noise reduction technology by monitoring the noise for the several video frames and defining and eliminating them consecutively at low light. Higher setting reduces noise much more but results in losing the sharpness and the tail effect or the motion blur for the fast moving target at low light.

Operating Instructions

6. DAY / NIGHT

DAY/NIGHT is used to control the setting during day-time and night-time operation. Select the mode according to the light condition and the camera types.

SMART IR can be set to reduce the saturation by the strong IR illumination in the night in any menu. Setting SMART IR in any menu is identically applied to other menu. Zero(0) turns off SMART IR and High setting avoids the saturation strongly but the corners will be darker accordingly. IR LED Control(AUTO/OFF) is available with IR LED model only. If IR LED is set to OFF, IR LED will be turned OFF but DAY or NIGHT is still determined by the built-in light photo sensor.

6-1. EXT

: DAY or NIGHT is determined by the built-in light photo sensor.
Camera with IR LED must be set to EXT.

6-2. AUTO

: Used when DAY or NIGHT is determined by light level through the lens and DAY from/to NIGHT is switched automatically by the scene brightness.

D↔N THRESHOLD, D↔N DELY and SMART IR can be set in the menu.

When EXPOSURE>AGC is less than 10, DAY/NIGHT AUTO is disabled and forcibly switches to ___(DAY) to avoid the malfunction. EXT, B/W (NIGHT) and COLOR(DAY) is independent on AGC level. When EXTERNAL IR LED is used with NON IR LED model, please set to IR LED MODE ON.

• D↔N THRESHOLD (0~20):

Sets the threshold level switching from/to DAY(color) or NIGHT(B/W).

Setting low level makes camera entered NIGHT at lower light level. High level makes camera exited NIGHT at brighter light level.

| DAY/NIGHT AUTO | | |
|----------------|---------------|-----------------|
| D | D↔N THRESHOLD | : : : : : : 10 |
| | D↔N GAP | : : : : : : 10 |
| | D↔N DELAY | 5s |
| | SMART IR | : : : : : : 10 |
| | RETURN | RET ↵ |

• D↔N GAP (0~15):

Sets the gap level switching from /to DAY(color) or NIGHT(B/W).

• D↔N DELAY (0~60s):

Sets the delay time when the camera switches from/to DAY(color) or NIGHT(B/W).

• SMART IR :

SMART IR can be set to reduce the saturation by the strong IR illumination in the night in any menu of EXT, AUTO and B/W(NIGHT). Setting SMART IR in

Operating Instructions

any menu is identically applied to other menu. Zero(0) turns off SMART IR and high level avoids the saturation strongly but the corners will be darker accordingly.

6-3. B/W(NIGHT)

: Forcibly removes IR cut filter and switches to B/W regardless of light level.

6-4. COLOR(DAY)

: Forcibly DAY/NIGHT is disabled and outputs color video.

6-5. COLOR D/N

: Forcibly Color mode, optimized for night condition. It is available to recognize colors of car, people and moving objects even at night. Parameters can be controllable & programmable according to circumstance. Application for bright circumstance at night such as downtown, civic area, street, mall and etc.



7. PICT ADJUST

7-1. WHITE BAL (default: ATW)

: ATW, ATWext, ONE PUSH and MANUAL are available for the white balance modes.

| PICTURE | |
|-------------|-----------------|
| ▶ WHITE BAL | ATW |
| SHARPNESS | : : : : : : 10 |
| COLOR GAIN | : : : : : : 10 |
| GAMMA | 0.50 |
| SHADING | OFF |
| RETURN | RET ↵ |

• ATW: White balance is continuously working along with the color temperature changes in the range of 2,000K~8,500K.

Operating Instructions

- **ATWext**: White balance is continuously working along with the color temperature changes in the range of 1,800K~11,000K.
- **ONE PUSH**: White balance works only during ● is pressed.
- **MANUAL**: White balance is fixed to the settings by R_GAIN and B-GAIN. This mode can be used only when the color temperature does not vary.

7-2. SHARPNESS (default: 10) : Adjusts the sharpness of video(0~20).

7-3. COLOR GAIN (default: 10) : Adjusts the color level of video(0~20).

7-4. GAMMA (default: 0.5) : Adjusts the gamma of video.

7-5. SHADING (default: OFF) :

ON enables to compensate the shade caused by wide lens setting.

8. SPECIAL

| SPECIAL | |
|---------------|-------|
| ▶ MIRROR/FLIP | OFF |
| PRIVACY | OFF |
| MOTION | OFF |
| PIXEL DEFECT | OFF |
| TITLE SET | ↓ |
| DISPLAY | ↓ |
| DEFOG | OFF |
| ZOOM MODE | OFF |
| RETURN | RET ↓ |

8-1. MIRROR/FLIP (default: OFF)

: Reverses the video left and right and/or up and down by MIRROR/FLIP.

- OFF : Normal display without mirroring or flipping
- Hor. : Video is reversed left and right
- Ver. : Video is reversed upside down
- HV : Video is reversed left and right and upside down.

When the video is reversed by Ver. or HV, then the joystick directions are reversed accordingly. This feature is very useful when a camera is installed in upside down.

8-2. PRIVACY (default: OFF)

: Set the Privacy zones which can be enabled individually by BOX or POLYGON are available to mask the video.

8-2-1. BOX : Set area to select privacy zones by square.

Operating Instructions

- ZONE NUM : Set a number to select a privacy zone from 1~10.
- ZONE DISP : ON enables a relevant privacy zone.
- H-POS, V-POS, H-SIZE and V-SIZE : Adjust the size and position of zone.
- COLOR : Select the color used for masking the zone form eight colors.
- TRANSPARENCY : Defines the transparency for the mask zone.

8-2-2. POLYGON : Set area to select privacy zones by polygon shape

- ZONE NUM : Set a number to select a privacy zone from 1~4.
- ZONE DISP : ON enables a relevant privacy zone.
- COLOR : Select the color used for masking the zone form eight colors.
- TRANSPARENCY : Defines the transparency for the mask zone.

8-3. MOTION (default: OFF)

: MOTION can detect the changes in the motion window and displays the results in blocks and/or a text message.

| MOTION | |
|-------------------|-----------------|
| ▶ SENSITIVITY |:.....: 10 |
| H-POS | 10 |
| V-POS | 5 |
| H-SIZE | 40 |
| V-SIZE | 25 |
| BLOCK DISP | OFF |
| MOTION OSD | OFF |
| SMART MOTION ZOOM | OFF |
| STAY ZOOMING | 5sec |
| RETURN | RET ↵ |

- SENSITIVITY : Adjusts the detection sensitivity for motion.
High value increases the sensitivity to detect the small motion easily. Too low sensitivity will cause the erratic detection by the tree leaves or the light level changes.
- H-POS, V-POS, H-SIZE, V-SIZE: Adjust the size and position of the detection window.
- BLOCK DISP : ON enables to display the blocks for the detected area.
- MOTION OSD : ON enables to display a text message, MOVING !!!,
- SMART MOTION ZOOM : ON enables to Automatic Zoom IN/OUT when motion is detected and also enables MOTION OSD to ON.

Operating Instructions

Area to be zoomed in by SMART MOTION ZOOM can be set at SPECIAL> MOTION> SMART MOTION ZOOM>ZOOM TARGET. Adjusting ◀, ▶ (Joystick) for ZOOM TARGET varies the viewing angle to be zoomed when the motion occurs. (See page No.27 "SMART MOTION ZOOM")
Set the video left and right and/or up and down by MIRROR/FLIP.

- STAY ZOOMING : Sets the duration time for zooming by Motion.



NOTICE

: Zoom functions such as POINTING ZOOM, PRESET ZOOM, FLEX ZOOM and SMART MOTION ZOOM are disabled intentionally to avoid the mis-focusing at low light at night.



CAUTION

- Set the direction of video by MIRROR/FLIP before SMART MOTION ZOOM setting. Otherwise ZOOM TARGET could be different from your intention.

8-4. PIXEL DEFECT (default: OFF)

- : Detects and compensates the white pixels which become defective. Once CALIBRATE is selected, the pixel calibration is initiated with lens closed and can't cancel.
- THRESHOLD : Defines the level of detection and low value detects more pixels. Be sure to set the value so that the pixels are uniformly blinking over the entire screen. Too low value will get the bad results because too many pixels are detected as the bad pixels and the maximum number of pixels for compensation will be filled by the upper area.
- EXECUTE '⏏' : Long pressing will execute the pixel calibration for the detected pixels. Menu will exit automatically after compensation.

8-5. TITLE SET

- : Camera title(name) can be set and edited up to 15 alpha numeric and symbolic characters from ASCII codes(ENGLISH only). ▲, ▼, ◀, ▶ moves the cursor to next input. Choose a character and '⏏' selects it. The selected characters are added and displayed on the top left Corner and the cursor moves right automatically for next input.
- SP - Space is inserted when pressed '●'
- BS – Cursor moves back when pressed '●'
- CLR – Clears all the characters on input line when pressed '●'.
- POS – To be able to set the title position by ▲, ▼, ◀, ▶ and ●.

Operating Instructions

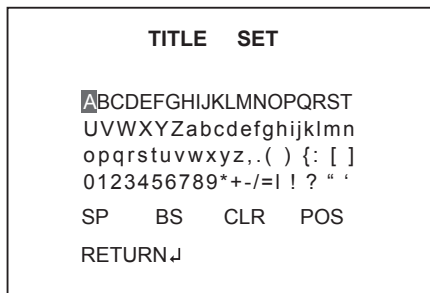

8-6. DISPLAY

- : Enables or disables to display the OSD.
- ID : ON enables to display the camera ID defined by SYSTEM>COMM. SETUP>CAM ID.
- TITLE : ON enables to display the camera title(name) set by SPECIAL>TITLE SET.
- D-ZOOM RATIO : ON enables to display the zoom ratio on the bottom right corner. DZx.x will display by multiplying the actual digital zoom ratio.

8-7. DEFOG (default: OFF)

- MODE
 - AUTO : Enhance the foggy video automatically according to status of scene.
 - MANUAL : Sets to enhance the foggy video manually regardless of status of scene.
- LEVEL : MID, HIGH, LOW
Video quality can be less in normal environments.

8-8. ZOOM MODE (default: OFF)

ON enables to select POINTING ZOOM, PRESET ZOOM or FLEX zoom modes.

8-8-1. POINTING ZOOM:

- H-POINTER, V-POINTER
- Able to set the location of zoom center D-Zoom is available DZ X1.1~ X8.0.
(See page No.28 "POINTING ZOOM")

| PRESET ZOOM | |
|----------------------------|-------|
| ▶ ZONE NUM | 1 |
| ZONE VIEW | ON ↵ |
| H-POS | 5 |
| V-POS | 5 |
| D-ZOOM RATIO | DX2.0 |
| STAYING ZOOMING | 3sec |
| RETURN | RET ↵ |
| By Remote Controller only. | |

Operating Instructions

8-8-2. PRESET ZOOM: Able to zoom in for the preset area by PTZ controller.

- ZONE NUM : Set a number to select a preset zoom from 1~ 4.
- ZONE VIEW : ON enables a relevant preset zone.
- H-POS and V-POS : Adjust the size and position of preset zone.
- D-ZOOM RATIO: Set the D-Zoom Ratio from DX 1.1~DX5.0
- STAYING ZOOMING : Sets the duration time for preset zoom area.

8-8-3. FLEX: Any place can be freely zoomed in by PTZ controller.

CAUTION

- Set the direction of video by MIRROR/FLIP before ZOOM MODE setting. Otherwise location of zoom center could be different from your intention.

TIP

Setting for Zoom Function with PTZ Controller

- Enter the MENU :

Press buttons 9+5+PSET (PRESET)



- Set the Preset Zoom :

Press buttons 1(or ~4)+PSET (PRESET)



- Working the Flex Zoom :

Moves the cursor UP/DOWN/LEFT/RIGHT with Joy stick on the screen where the position to zoom in/out.

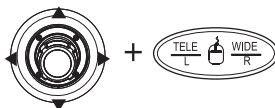

- D-Zoom IN: Press button TELE or Spin the joystick to clockwise.
- D-Zoom OUT: Press button WIDE or Spin the joystick to counter-clockwise.

- Select or Choose value in the MENU :

Press button OPEN (IRIS OPEN)



- Exit the Preset/Flex Zoom mode :

Press buttons 3+4+PSET (PRESET)



Operating Instructions

9. SYSTEM

| SYSTEM | |
|-----------------|---------|
| ▶ TV SYSTEM | EU(PAL) |
| RESOLUTION | 1080P |
| COMM. SETUP | ↓ |
| LANGUAGE | ENG |
| FACTORY DEFAULT | NO |
| RETUTN | RET ↓ |

9-1. TV SYSTEM (default: US or EU)

: Selects HDTV standards for US(60HZ) or EU(50HZ). By this selection, 2nd analog video output switches to NTSC or PAL accordingly.

9-2. RESOLUTION (default: 1080P)

: Three resolutions, 1080P(SCALED)/720P(CROPPED) are available. 1080P outputs 1920x1080 video at the frame rate of 30P/25P.

720P(SCALED) Image is scaled down from 1080P and outputs 1280x720 video without loss of field of view at the frame rate of 30P/25P.

720P(CROPPED) image is cropped at the center area from the image sensor and outputs 1280x720 video at the frame rate at 60P/50P but the image refresh rate is 30P/25P. Cropped image has narrowed field of view

9-3. COMM. SET UP

: COMM. SETUP defines the CAM ID, BAUD RATE and PROTOCOL.

Data length, stop bit and parity are fixed to 8bit, 1stop bit and no parity bit.

- CAM ID – Assigns the camera ID from 1~255 for the comm. address.
- BAUD RATE – Selects the baud rate from 2400~115200.
- PROTOCOL – Selects the comm. Protocol from PELCO-D/P or VISCA.

(Refer to 'TIP' page NO. 25)

9-4. LANGUAGE (default: ENG)

: 8 languages are available for ENGLISH, JAPANESE, GERMAN, FRENCH, ITALIAN, SPANISH, POLISH and TURKISH.

9-5. FACTORY DEFAULT (default: NO)

: RECALL  roads and saves the factory defaults.

Operating Instructions

Detail Function Description

SMART MOTION ZOOM

SMART MOTION ZOOM enlarges the certain area defined by a yellow window to the full sized image when the motion is detected in the black window.

SMART MOTION ZOOM window can be re-sized by adjusting D-ZOOM RATIO and moved by H-POINTER and V-POINTER.

UNLIKE the conventional zoom which can zoom in/out the center area of image only, by the flexible zoom location and area, SMART MOTION ZOOM differentiates its usefulness from others.

That is, a conventional camera installed on the corner of ceiling can zoom the center of the floor in a room and result in losing the image of door on the side wall. However, SMART MOTION ZOOM can be set to see the door side and zoom in that area without missing the IMPORTANT security point.

| SMART MOTION ZOOM | |
|-------------------|-------|
| ▶ ZONE VIEW | OFF |
| H-POS | 10 |
| V-POS | 10 |
| D-ZOOM RATIO | DX2.0 |
| MOTION CHK CUNT | 3 |
| RETURN | RET ↓ |

- H-POINTER (10): Moves MOTION ZOOM area(Yellow window) horizontally.
- V-POINTER (10): Moves MOTION ZOOM area(Yellow window) vertically.
- D-ZOOM RATIO (MZ2.0): Sets the area size to be Digital zoomed when the motion occurs in the black window.
- MOTION CHK COUNT (3) - SMART MOTION ZOOM is activated after the motions in MOTION CHK COUNT are detected in a certain period.
For example, '1' immediately initiates SMART MOTION ZOOM by the motion detected once. High count number enables SMART MOTION ZOOM with sureness but with delay and less sensitivity.

Operating Instructions

POINTING ZOOM

This camera has a very useful and powerful feature, POINTING ZOOM, which can zoom in/out any area.

UNLIKE the conventional zoom which can zoom in/out the center area of image only, by the flexible zoom location and area, POINTING ZOOM differentiates its usefulness from others. That is, a conventional camera installed on the corner of ceiling can zoom the center of the floor in a room and result in losing the image of door on the side wall.

However, POINTING ZOOM can be set to see the door side and zoom in that area without missing the IMPORTANT security point.

POINTING ZOOM can be activated by the joystick operations of ▲ for zoom in and ▼ for zoom out or via web viewer, while SMART MOTION ZOOM is activated by the result of motion detection in the defined area.

If Zoom ratio becomes out of optical zoom ratio, it automatically turns to Digital Zoom.

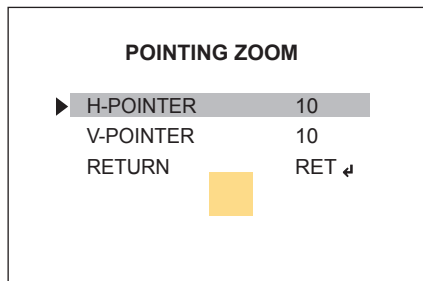

- H-POINTER (10): Sets the horizontal location of area to be zoomed by POINTING ZOOM.
- V-POINTER (10) : Sets the vertical location of area to be zoomed by POINTING ZOOM

Operating Instructions

* EXAMPLE OF SMART MOTION & POINTING ZOOM



[At the ATM nearby ENTERANCE]

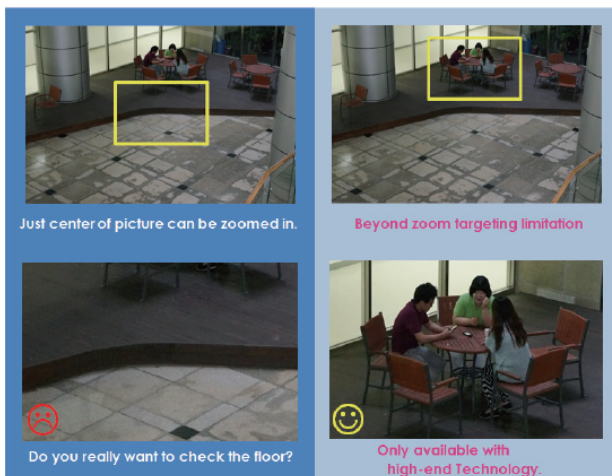

[At the LOBBY]

Specifications

| ITEM | HDB-2080M2810IR D |
|--------------------------------|---|
| Imaging Sensor | Panasonic 1/3" Progressive Scan CMOS Sensor |
| Effective Pixels | 1,944(H) x 1,092(V) |
| Min.Illumination | 0.0005 Lux @ (AGC MAX, DSS x2) |
| Video Resolution | 1920x1080 (30p/25p) |
| TV System | EU(PAL) |
| Sync. System | Internal |
| Format | 16:9 Video format for most popular commercial HDTV monitors |
| Selectable Video Output | EX-SDI: 270Mbps Visually lossless compression thru 75Ω BNC conn. HD-SDI: 1.485 Gbps, (SMPTE 292M) thru 75Ω BNC conn. |
| Video Sub-out | NTSC/PAL standard, 1Vp-p @75Ω composite |
| HD Trans. Distance | EX-SDI: 350m+ (RG59, 5C2V) HD-SDI: 80~140m(RG59, 5C2V), 230m(Belden 1694A) |
| S/N Ratio | More than 50dB (AGC OFF) |
| Lens Type | f=2.8~10mm F1.4 Mega pixel DC Auto Iris Vari-focal lens |
| LEDs | Built-in 40pcs x 850nm IR LEDs |
| Day & Night | TDN by dual filter switcher, AUTO, COLOR, B/W, EXT, COLOR D/N |
| Exposure | Auto / Manual / Flickerless |
| Flip | OFF/ H/ V/ HV FLIP |
| White Balance | ATW / ATWext / One Push / Manual |
| WDR | True WDR by dual scan images in two frames at 30fps |
| Special Features | FOCUS ASSIST, SMART MOTION ZOOM, POINTING ZOOM, PRESET ZOOM, FLEX ZOOM |
| Functions | NORMAL, WDR, D-WDR, 3DNR, Motion Detection, Privacy Mask, Defog, D-Zoom(~8x), Sens-up(~x32), BLC/HLC, Title Set, Pixel Defect Compensation, Lens Shade Compensation, LED ON/OFF control |
| Remote Control | RS-485(Pelco-D/P) |
| Languages | English, German, French, Italian, Spanish, Polish, Japanese, Turkish |

Specifications

| | |
|---------------------------|---|
| Installation Temp. | -20°C ~ +50°C (Humidity : 30%RH ~ 80%RH) |
| Operating Temp. | -50°C ~ +50°C (Humidity : 30%RH ~ 80%RH) |
| External Dimension | 108mm(W) x 100mm(H) x 267mm(L)_with Bracket / About 1.35Kg |
| Mechanical Feature | IP67, Aluminum Cast, Dual window, One touch 3-Axis locking bracket, Easy Installation Pad, External Zoom/Focus adjustment, Heating function |
| Power Source | AC24V~11VA/DC12V=550mA, 7W Circuit protection against faulty connection in power polarity. Isolated power supply against ground loop problem. |

(*) Design and specifications are subject to change for product improvements without prior notice.



eneo® is a registered trademark of
VIDEOR E. Hartig GmbH
Exclusive distribution through specialised
trade channels only.

VIDEOR E. Hartig GmbH
Carl-Zeiss-Straße 8
63322 Rödermark/Germany
Tel. +49 (0) 6074 / 888-0
Fax +49 (0) 6074 / 888-100
www.videor.com
www.eneo-security.com

Technical changes reserved

© Copyright by VIDEOR E. Hartig GmbH
Version 04/2015